

DOUBLE-BALANCED MIXERS

Get the Most from Mixers

Here's a straightforward explanation of mixer technology, performance specs, measurement techniques and hints to get the most value, from a mixer manufacturer. Plus a number of application suggestions.

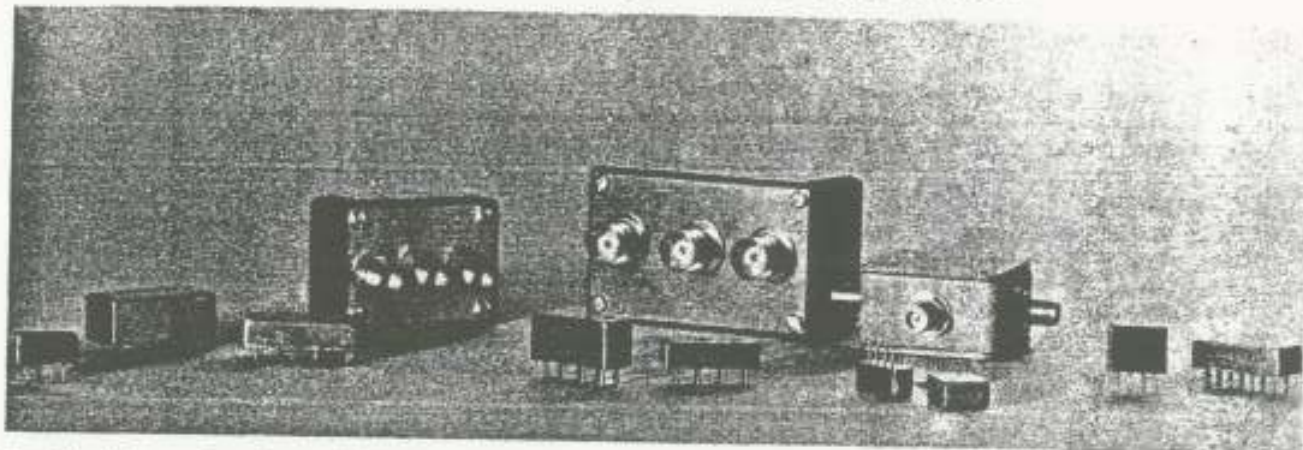

Double-balanced mixers (DBMs) have become a standard component in communications systems, microwave links, spectrum analyzers and ECM equipment. Used properly, DBMs allow systems designers to achieve minimum levels of distortion with a high degree of isolation from interfering signals. However, used improperly, DBMs can degrade systems performance. Similarly, incorrect interpretations of mixer specifications can be costly. Underspecify and expect marginal performance; overspecify and pay for unnecessary device characteristics.

To properly apply and specify a double-balanced mixer, it is helpful to understand how it works, what factors influence distortion and how performance is measured. Mini Circuits offers this article to enhance the engineers practical knowledge.

How a single-balanced mixer works

To begin, let's analyze a simplified version of a typical single-balanced mixer, shown in Fig. 1.

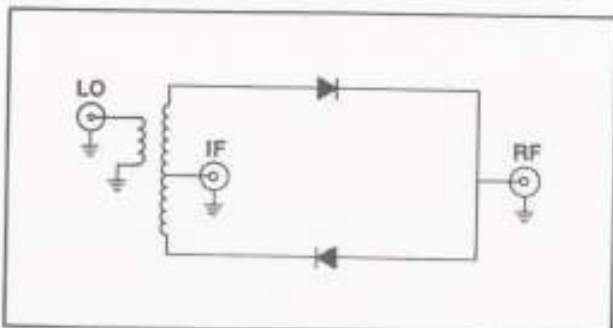

1. A single-balanced mixer offers good isolation between LO and rf but poor isolation between rf and i-f.

The characteristic of the single-balanced mixer is that there is isolation between the local oscillator (LO) and the RF, attributable to the inherent circuit balance between the LO and RF. However, there is no balance between the RF and IF; examination of Fig. 2 with its loop currents explains why.

When the LO signal is applied, assume the polarity shown on the LO input-transformer; the direction of LO currents would then appear as shown for i_{LO1} and i_{LO2} . The total current through the IF and RF source resistances consists of the sum of the currents from the LO and RF inputs. First, consider what happens when the LO signal is applied. With the polarity shown at the LO transformer secondary, current flow is clockwise for i_{LO1} and i_{LO2} . These currents flow through RF and IF source resistances. Looking at the current flow through the RF source resistance R_{RF} , there would be complete cancellation of the LO component (assuming the i_{LO} currents were exactly identical in the amplitude and phase).

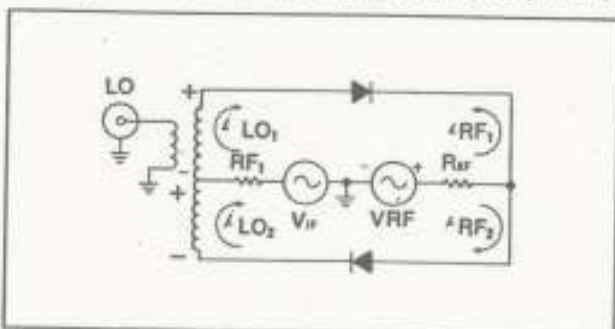

2. Examination of loop currents in a single-balanced mixer explains poor rf to i-f isolation.

Similarly, examining the local oscillator (LO) current flow through the IF source resistance, R_i , again cancellation would occur. Thus no LO power would be developed at either the IF or RF outputs. The single-balanced mixer, therefore, provides isolation from the LO to both the RF and IF.

Now, let's analyze what takes place when the RF signal is applied. Assuming the polarity shown for the RF source, two mesh currents will flow, i_{rf} and i_{if} as shown. Both i_{rf} and i_{if} add as they pass through the IF source resistance, R_i , and cancellation takes place. Thus, for a single-balanced mixer, there is no isolation between the RF and IF.

How about the balance between the RF and LO ports? Since i_{if} flows through the upper winding of the LO transformer in the opposite direction as i_{rf} in the lower winding, no voltage would be developed at the LO terminal. Therefore there is isolation between the RF and LO.

All previous references to conditions of balance are based on currents being equal in amplitude. In actual practice, the following factors tend to upset the ideal conditions. Variations in transformer balance and unequal diode impedance will cause deviations in current balance. At high frequencies, above 100 MHz, wiring capacitance, transformer winding capacitance and physical location of components will also upset balance. As operating frequency increases, balance will fall off and a lower isolation specification will appear on the mixer data sheet.

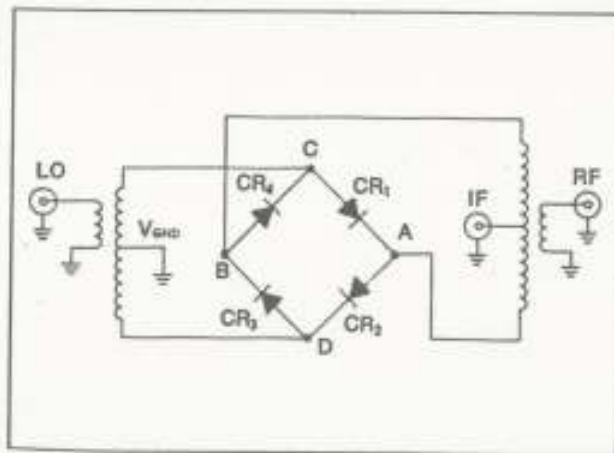

3. The symmetry of a double-balanced mixer's configuration is the key to the excellent isolation offered between LO, rf and i-f ports.

Double-balanced mixers offer improved isolation

A typical schematic for a double-balanced mixer is shown in Fig. 3. Let's now examine how balance is achieved. If CR_1 and CR_2 and the LO transformer are symmetrical, then the voltage at point A is the same as the center-tap of the transformer, or ground. Similarly, if CR_3 is equal to CR_4 , the voltage at B is the same as V_{end} . Therefore, there is no voltage across A & B and no voltage across the RF or IF ports. This illustrates how isolation is obtained between LO and RF and IF ports.

Now let's look at the RF input. If CR_1 is equal to CR_3 and CR_2 equal to CR_4 , the voltage at C will be equal to that at D. There will be no voltage difference between C-D and thus no RF will appear at the LO port. From symmetry, it can be seen that the voltage at the IF port is the same as the voltage at C, D or zero; thus there is no RF output at the IF port. The simplified sketch for the above is shown in Fig. 4.

Again assumptions for balance are based on transformer symmetry and diodes being equal. As with single-balanced mixers, unbalance and a subsequent drop in isolation will result from diode junction capacity differences and transformer winding variations. Here's a rule-of-thumb approximation for isolation: as frequency of operation is increased, isolation tends to fall off at the rate of 5 dB per octave. Thus, for example, if you were to measure 40 dB isolation at 300 MHz, you could predict isolation of 45 dB at 150 MHz by using the 5 dB per octave estimate.

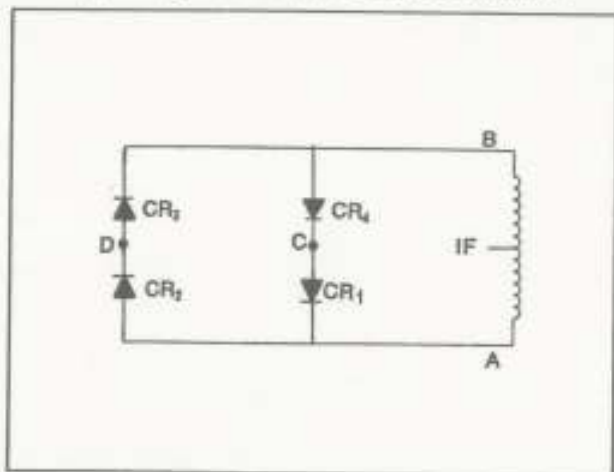

4. I-f leakage to rf and LO ports are minimized in a dbm by use of balanced transformers and matched diodes.

PROMPT SERVICE / ONE WEEK DELIVERY

Mini-Circuits

Get the Most from Mixers

Table 1. PROPERTIES OF DOUBLE-BALANCED MIXERS

PROPERTIES	IMPLICATIONS
<ul style="list-style-type: none">• Inherent isolation between LO & RF, IF ports• Inherent isolation between RF & LO, IF ports• Inherent isolation between IF & LO, RF ports	<ul style="list-style-type: none">• No filters necessary — thus broadband — can be used for suppressed-carrier modulation
<ul style="list-style-type: none">• IF DC coupled	<ul style="list-style-type: none">• Can be used as phase detector
<ul style="list-style-type: none">• Isolation depends on symmetry of transformers and diodes	<ul style="list-style-type: none">• High isolation — can be used as electronic switch/attenuator by injecting DC current to cause unbalance
<ul style="list-style-type: none">• Response to RF input same for either polarity of RF signal amplitude	<ul style="list-style-type: none">• High rejection of even-order harmonics

Whether the RF has a positive polarity or negative polarity, the inherent response of the DBM circuit is the same. For example, if a sine wave is applied, there would not be a lower conversion loss if the input was positive and a higher conversion loss for a negative-going input; the response is equal and independent of RF signal polarity. Again, it is assumed the diode characteristics are symmetrical for positive and negative input signal polarities.

Basically, the three major considerations of the double-balanced mixer are the inherent isolation between the various ports, as summarized in Table 1. The implications of these isolation properties appear in the variety of applications to which the double-balanced mixer can be used.

Another inherent characteristic of a DBM that suggests an area of application is the fact that the IF point is DC coupled to the diodes. This has two significant implications: (1) the frequency response is from DC to some very high frequency, which lends itself to use as a phase detector in phase-locked loop arrangements and (2) the high isolation between ports enables the DBM to be used as an electronic switch or attenuator. If the excellent balance between ports is deliberately upset so that isolation is degraded, some feedthrough would take place. The degree of feedthrough or isolation can be set by applying a DC current or voltage at the IF port. The resultant unbalance determines the level of attenuation. Typically, 10 to 20 mA current will change the insertion loss between LO and RF to as low as 3 dB or less. As the current through the IF port is varied, the balance between LO and RF will be altered; a predetermined amount of current will establish a preset degree of attenuation. Since the IF port response extends from DC to some very high frequency, very fast switching or change of attenuation characteristics is practical. Present-day switching techniques using PIN diodes as switches are not practical at lower frequencies because the PIN characteristics are lost below 1 MHz. With a DBM, satisfactory attenuator performance can be attained down to 500 Hz.

The disadvantage of the DBM in switching/attenuator application is the generation of harmonics of the RF input, which may be undesirable in some systems designs.

Consider three different devices (not just mixers), as shown in Fig. 5, with a sine-wave input applied to each. In case (A), the output of the linear device will be identical in waveform, although not necessarily in amplitude. In case (B), unsymmetrical distortion due to unequal voltage sensitivity would develop an output that is flat-topped on one half cycle. And finally, non-voltage-polarity sensitive device could produce symmetrical flattening as shown in case (C). Mathematically, the output of case (A) is a constant K_1 times the input. In case (B), as a first approximation, the output is a constant K_1 times the input plus another constant K_2 times the input squared. In case (C), where distortion is symmetrical, the output is in the form of a constant K_1 times the input plus another constant K_2 times the cubic of the input. Case (C) applies for the double-balanced mixer where all circuit elements are balanced and distortion is uniform for both voltage polarities of the signal. The important point here is that the output of a DBM can be described, on first approximation, as a cubic. In practice, of course, no device is perfect and unbalances will occur. This means that, along with the cubic term, there will also appear second, fourth, etc. terms with the third-order the predominant term. In the double-balanced mixer, a third-order term will always exist because of some limiting factors that determine the saturation of the mixer, namely the diodes and transformer.

Single-tone, or harmonic intermodulation, distortion appears when only one input signal at the RF port combines with the LO signal. The interaction of the LO and its harmonics with the RF input signal and its harmonics produce higher-order distortion products as shown in Table 2, for models SRA-1, SRA-2, ZAD-1 and ZAD-2. The distortion levels are indicated by the number of dB below the output level of the RF input frequency \pm LO frequency; LO fre-

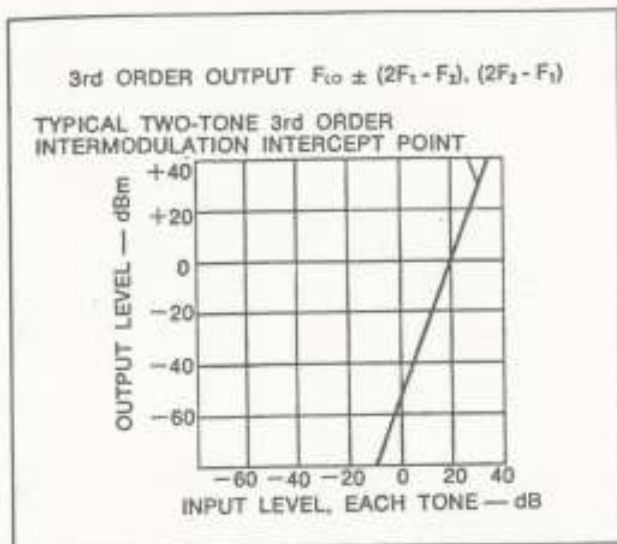

6. Although the intercept point is fictitious since mixers are not operated at this level, it is a convenient figure of merit for dBm evaluation.

Thus it is possible to predict the RF input level allowable to keep two-tone, third-order response to a given level in a systems design. To use a mixer properly, it is necessary to relate the two-tone input and third-order output levels involved to avoid generating excess distortion and compromising the final design.

Not as obvious, but important, is the effect of increasing operating frequency on the mixer two-tone, third-order distortion characteristics. Generally, performance is better at low frequencies and drops off as frequency is increased. For high-frequency mixers (500 MHz), fall-off starts to occur somewhere between 50 to 100 MHz.

Often a mixer data sheet does not specify intercept point, so a rule-of-thumb estimate can easily be made by examining the 1 dB compression point. As RF input level is increased, there is a point where the conversion loss will increase. A convenient point of reference is a 1 dB compression point. As RF input is increased, IF output should follow in a linear manner. However, after a certain point, the IF output increases at a lower rate until the mixer output becomes fairly constant. When the IF output cannot follow the RF input linearly, and deviates by 1 dB, this point is called the 1 dB compression point. Now the conversion loss is 1 dB higher than it was when the RF input signal was smaller. The importance of this figure is its utility in comparing dynamic range, maximum output and two-tone performance of various mixers.

As a rule-of-thumb, the intercept point is approximately 10 to 15 dB higher than the 1 dB compression point; at low frequencies about 15 dB, and at higher frequencies about 10 dB. See Fig. 7.

How to measure mixer performance

A manufacturer with integrity does not play the "numbers game" when preparing specification data on his product line. Mini-Circuits Laboratory's policy for product measurement and specification is straightforward — presents the honest facts so the design engineer can evaluate product data for his circuit and system requirements and arrive at a proper design decision.

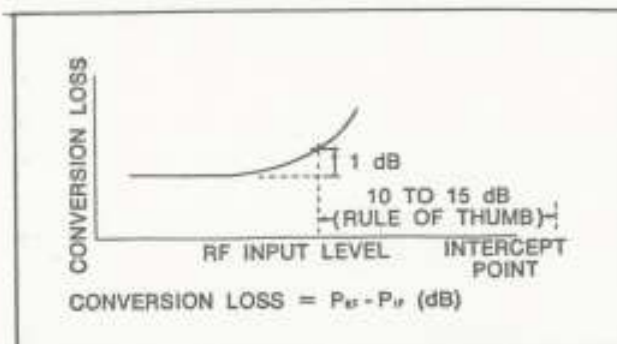

7. The 1 dB compression point is an indication of a dbm's dynamic range and maximum power capabilities.

A 50-ohm broadband system is used for all factory measurements. It offers the customer a convenient and consistent means to obtain correlation with data prepared by Mini-Circuits.

For conversion loss measurements, Fig. 8a, fixed attenuator pads are connected to all three ports so the mixer sees 50 ohms at the frequency of interest and ALL harmonics. An RF input level of -11 dBm is deliberately selected. Here's why: assuming a typical 6 dB conversion loss, the IF output would be -17 dBm. Mini Circuit's mixers provide LO-IF isolation typically in the order of 50 to 60 dB. Normally, the LO input is $+7$ dBm and thus with 50 dB isolation, the LO leakage level of -43 dBm would be much lower than IF output. Therefore the RF input level is high enough to operate the mixer in its linear range and not low enough to allow LO leakage to destroy the integrity of the measurement.

For the IF Power level measurement, a crystal filter is included before the broadband RF voltmeter, to reject all responses other than the desired IF. When a crystal filter is used, LO leakage would have no effect on the conversion loss measurement since it would not reach the RF voltmeter.

There are two general techniques for measuring isolation, both requiring 50 ohm terminations at the unused ports. When measuring LO-RF isolation, see Fig. 8 (b), a pad is placed between the generator and DBM to ensure a 50-ohm-impedance. Also, a 50-ohm termination is connected to the IF port and the power at the RF port is measured to obtain the isolation performance.

Get the Most from Mixers

When measuring isolation from RF-IF or RF-LO, the power applied at the RF port is set at a high level to make sure the diodes have sufficient drive power. This RF power level will be higher than encountered in actual DBM usage. However, the measurement results can be considered quite accurate.

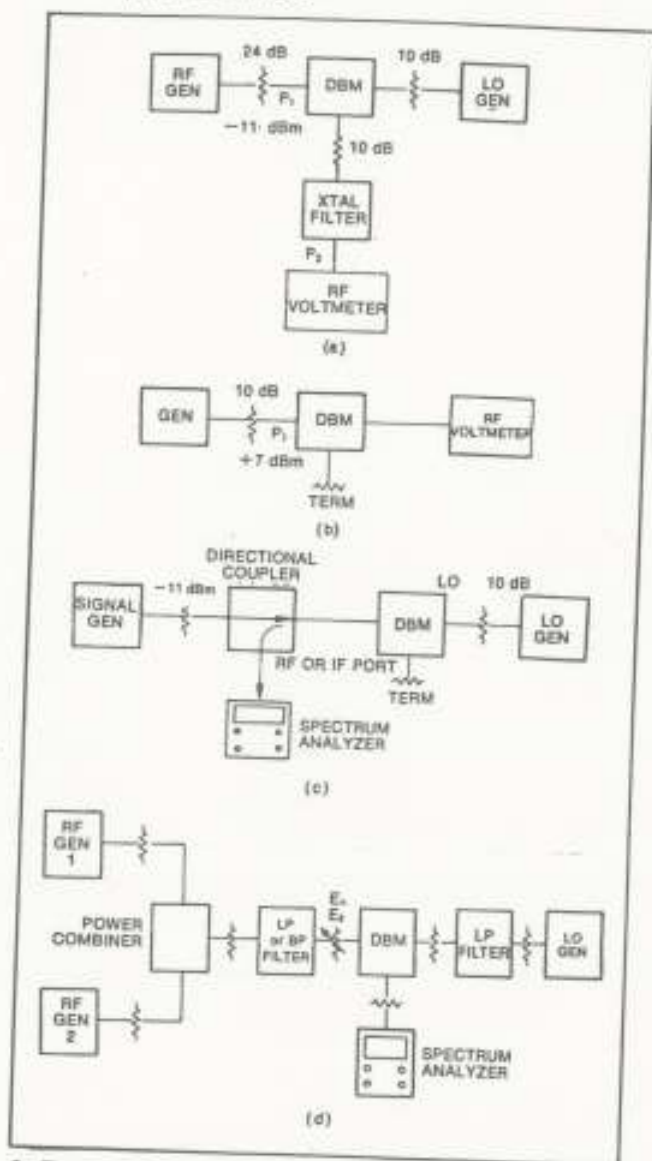

8. Test measurement setups for (a) conversion loss, (b) isolation, (c) VSWR and (d) two-tone, third-order distortion.

The RF voltmeter technique actually produces isolation specs that are conservative since many applications normally involve narrow-band circuits and filters that would eliminate the harmonics. By assuming everything measured on the RF voltmeter is due to the fundamental and that harmonics are not present, mixers supplied by Mini-Circuits perform better than expected from data sheet specs.

Replacing the RF voltmeter by a spectrum analyzer enables the following improvement in measurement integrity. First, the power at the fundamental frequency of measurement can be observed. Now, for broadband applications, the effects of harmonics can be judged. For narrow-band applications, only the fundamental need be considered. By using the spectrum analyzer technique, the design engineer can avoid overspecifying his dBm isolation requirement with subsequent cost savings.

Here's another important advantage of the spectrum analyzer technique. When RF-IF or RF-LO measurements are made, the RF level can now be set at the normal operating level under which the dBm will be used.

VSWR measurements are made under the same dynamic conditions that the mixer would encounter in practice, see Fig. 8 (c). First, let's consider VSWR measurement at the RF port. An LO signal is terminated in 50 ohms. The RF generator supplies an input level corresponding to linear mixer operation. With the double-balanced mixer disconnected from the directional coupler, a reference level is obtained (all the RF power is reflected back). The amount of reflected signal depends on the directional coupler used; a 20 dB coupler would establish a reference level 20 dB below the RF input. Next, the mixer is connected to the output of the directional coupler. The spectrum analyzer acts as a narrow-band filter and allows observation at the RF input frequency. The RF power reflected back from the mixer is display and can be measured by the calibrated scale on the spectrum analyzer.

The VSWR at the IF port is measured in a similar fashion. In this case, the RF port is terminated in 50 ohms.

Broadband mixers, it should be noted, exhibit a different VSWR characteristic at different frequencies. Factors causing this include circuit resonances and changes in diode impedances as the LO power level changes. Also of importance is the fact that the input impedances of the various ports are load dependent, even though they are isolated from each other. At high frequencies, this effect is more noticeable since isolation tends to drop as frequency increases.

Two-tone, third-order intermodulation distortion takes place when two incoming signals arrive at the mixer RF port and interreact. The signals resulting from the interreaction may be objectionable within the IF response.

The test setup for checking two-tone, third-order response is discussed in detail, see "Chances are your two-tone, third-order IM measurements are inaccurate." Please request this application note from the factory.

Two-Tone Third Order Intermodulation Distortion

This distortion term describes the degree by which the mixer conversion loss is non-linear. The two-tone third order distortion term is the amount of signal level at the IF output generated as a result of a third order frequency term. The frequency term corresponding to third order is $(2fR2 - fR1) \pm fL$, where fR represents the RF input signal and fL represents the LO drive.

Normally, this parameter is not specified on the data sheet because it is dependent upon frequencies, terminating impedances, and levels.

Intercept Point Two-tone third-order intermodulation distortion is a measure of the third-order products generated by a second input signal arriving at the R port of a mixer along with the desired signal. A popular method of determining the suppression capability of a mixer is the "third-order intercept" approach. The third-order intercept point is a theoretical point on the RF input versus IF output curve where the desired input signal and third-order products become equal in amplitude as RF input is raised.

A convenient way to describe intermodulation products relative to input signal level is to state the relative difference between the two in dB; for example, a mixer may be specified as 60 dB down for two-20 dBm input signals. This means the mixer, with two-20 dBm signals as its input, will suppress third-order products by 60 dB. Now if the input level is reduced an additional 10 dB, the third-order product level would decrease by a factor of three, or 30 dB. The difference between the two would be 20 dB and thus, the mixer would offer 80 dB suppression with two -30 dBm signals at its input. With another 10 dB drop in signal level, third-order products would drop another 30 dB with a difference of 20 dB between the two. Thus, two -40 dBm signals would produce third order products suppressed by 100 dB. When will the two types of signal (input and third-order) theoretically become equal? The original input levels were -20 dBm and thus, the third-order products were 60 dB lower, or -80 dBm. Now if the input is raised 30 dB to ± 10 dBm, the third-order products would be increased by a factor of three or 90 dB; a 90 dB increase added to the original -80 dBm, thus establishing equal amplitude for the desired and distorted signals.

Graphically, the intercept point is obtained by linearly extending the desired signal curve past the compression point until it intersects the third order curve.

A rule-of-a-thumb method for determining the intermod level is as follows: (1) find the 1 dB compression level (this is the RF input power level that caused the conversion loss to increase by 1 dB). (2) determine the intercept point. At the low end of the frequency band, this point is about 15 dB above the 1 dB compression point. As the mid to upper frequency band is approached, the intercept point drops to about 10 dB above the 1 dB compression point. (3) Multiply the difference between the intercept point and RF input level (equal RF levels) by the order of harmonic. (4) Subtract this number from the intercept point. This is the intermod level. For example: Given a) 1 dB compression point at RF input of +1 dBm. b) RF input level -10 dB RF used at low end of band. c) what is third-order intermod level? Solution: (1) Compression point is +1 dB min. (2) Intercept point equals 1 dBm +15 dBm = +16 dBm. (3) +16 dBm - (-10 dBm) equals +26 dB. 26 dB times third-order = -78 dB. (4) Intermod level equals +16 dBm -78 dB = -62 dBm.

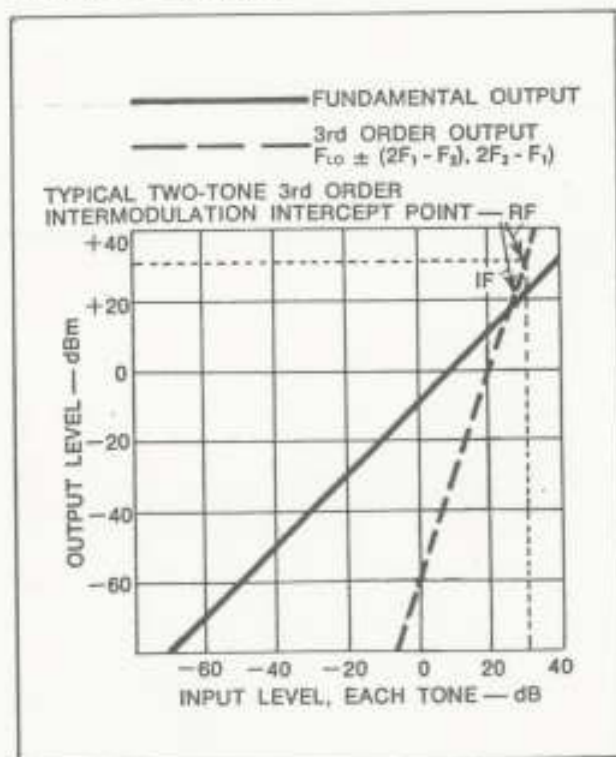

Directional Coupler Application and Operation

Mini-Circuits

Mini-Circuits directional couplers are reactive devices featuring very low insertion loss. The basic operation of the directional coupler is to operate on an input so that two output signals are available. However, when the input is applied to an opposite port, only one output signal is available. The directional coupler has the following theoretical characteristics.

- 1) The output signals are unequal in amplitude. The larger signal is at the main line. The smaller signal is at the coupled line.
- 2) The main line insertion loss depends on the signal level at the coupled line. The relationship is as follows:

Theoretical Minimum	
Main Line Insertion Loss	Coupling
3 dB	3 dB
1.2 dB	6 dB
.46 dB	10 dB
.14 dB	15 dB
.04 dB	20 dB

- 3) There is high isolation between the coupled line and the output of the main line.

A schematic representation of the coupler is as follows:

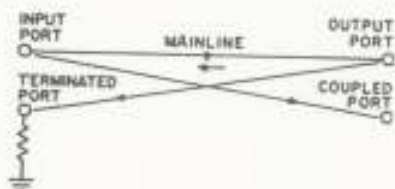

Key characteristics of a directional coupler include coupling coefficient, coupling flatness, insertion loss, directivity and isolation, defined as follows:

Coupling coefficient expresses the ratio, in dB, of the input port power to the coupled port power with all ports properly terminated. Mini-Circuits offers a variety of directional couplers with coupling values ranging from 10 to 21 dB.

Coupling flatness indicates the maximum peak-to-peak variation in coupling coefficient over the frequency range covered by the directional coupler.

Insertion loss relates to the change in output port power due to the insertion of the directional coupler into a system, considering all ports properly terminated.

Isolation reveals the unbalance due to slight variations in device symmetry. If the coupler is perfectly symmetrical, the signal applied to the output port will split between the input port and the terminated port. Any unbalance will allow a leakage signal to develop at the coupled port. The ratio, in dB, of this leakage signal to the output port signal is termed the device's isolation.

Directivity is a significant factor in coupler selection. The output power at the coupled port is measured when input power is transmitted in the desired direction; then output power at the coupled port is measured with the same amount of input power transmitted in the opposite direction. The ratio, in dB, of the two powers at the coupled port expresses the directivity. All ports are considered properly terminated. Directivity is equal to the isolation in dB, minus coupling in dB, and is a measure of the dynamic range at the coupled port.

Mini-Circuit's full line of directional couplers provide excellent performance. They feature 1) broad bandwidth 2) low insertion loss, as low as 0.1 dB 3) directivity as high as 45 dB and 4) a wide range of coupling values, from 10 dB to 21 dB.

The high performance characteristics of these units enable the following signal processing functions to be accomplished:

- Measure Incident and Reflected Power to Determine VSWR
- Signal Sampling
- Signal Injection
- Signal Generator/Oscillator Leveling
- Power Flow Monitoring

DIRECTIONAL COUPLER FREQUENCY SELECTION GUIDE

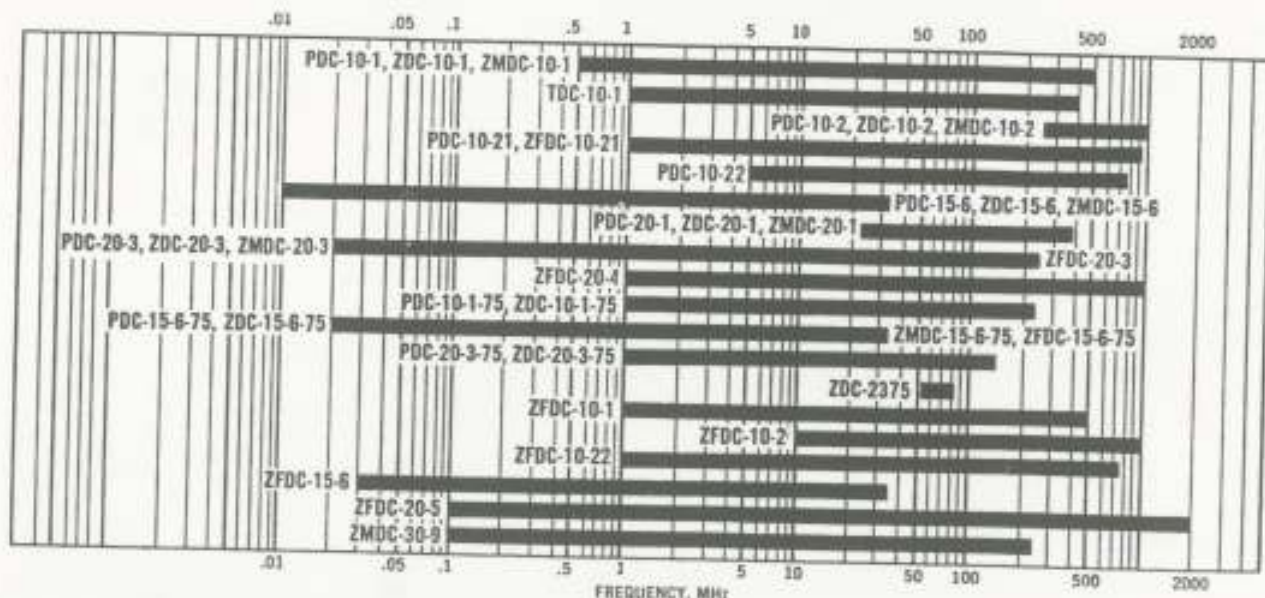

PROMPT SERVICE / ONE WEEK DELIVERY

Mini-Circuits